

Auto Temp Control Module

Intellitec's Automatic Temperature Control (ATC) Module is designed to maintain the temperature inside a vehicle through the control of the heating and air conditioning circulating fan/s, and water and Freon valves. This module provides five, individually fused outputs to feed the air conditioning/heating fan, the heater water valve, and the evaporator Freon valve. It is controlled from a remote switch panel with a single pole, double throw, center off switch for heat or cool mode select, and a potentiometer to select the desired temperature. The temperature sensor is mounted remotely to sense the temperature close to the occupants for best performance.

In operation, the fan speed changes with how far the actual temperature is from the set temperature. If the actual temperature is more than 5 degrees from the set temperature, the appropriate valve will open, and the fan will operate at high speed. As the temperature approaches the set temperature, the fan speed drops to medium. When the temperature reaches the set temperature, the fan will drop to slow. When the temperature passes the set point, the valve (water for heat, Freon for air conditioning) will close. The fan will continue to run at low speed.

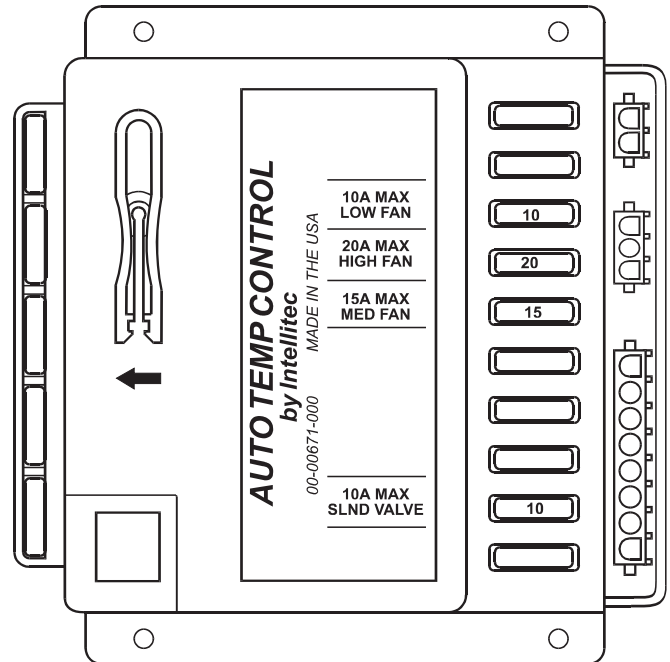

For applications where more than one fan is being used, the module is equipped with an output that can be connected to the Switch input of an Intellitec Fan Speed Module (Part No. 00-00662-000). With this connection, all the fans in the system will operate at the same speed from the ATC module.

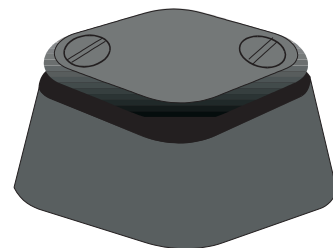

TEMPERATURE SENSOR
ACTUAL SIZE



Intellitec

131 Eisenhower Lane North
Lombard, IL 60148
630.268.0010 / 1.800.251.2408
FAX 630.916.7890

Auto Temp Control Module

How It Works:

The Automatic Temperature Control operates the three speeds of the HVAC fan, the water and Freon valves through five relays with individually fused outputs. The module, used in conjunction with a remote temperature sensor attempts to maintain a constant temperature, in a vehicle, by adjusting the fan speed and controlling the heater water and evaporator Freon flows.

Specifications:

	12 Volt	24 Volt
Part Number	00-00671-000	00-00671-240
Maximum Continuous Carry Current		
Fan Outputs	25 Amps Max.	25 Amps Max.
Control Valve Outputs	10 Amps Max.	10 Amps Max.
Temperature Adjustment Range	65° to 85° F.	65° to 85° F.
Maximum Ambient Temperature	185° F.	185° F.
Minimum Ambient Temperature	-40° F.	-40° F.

Schematic:

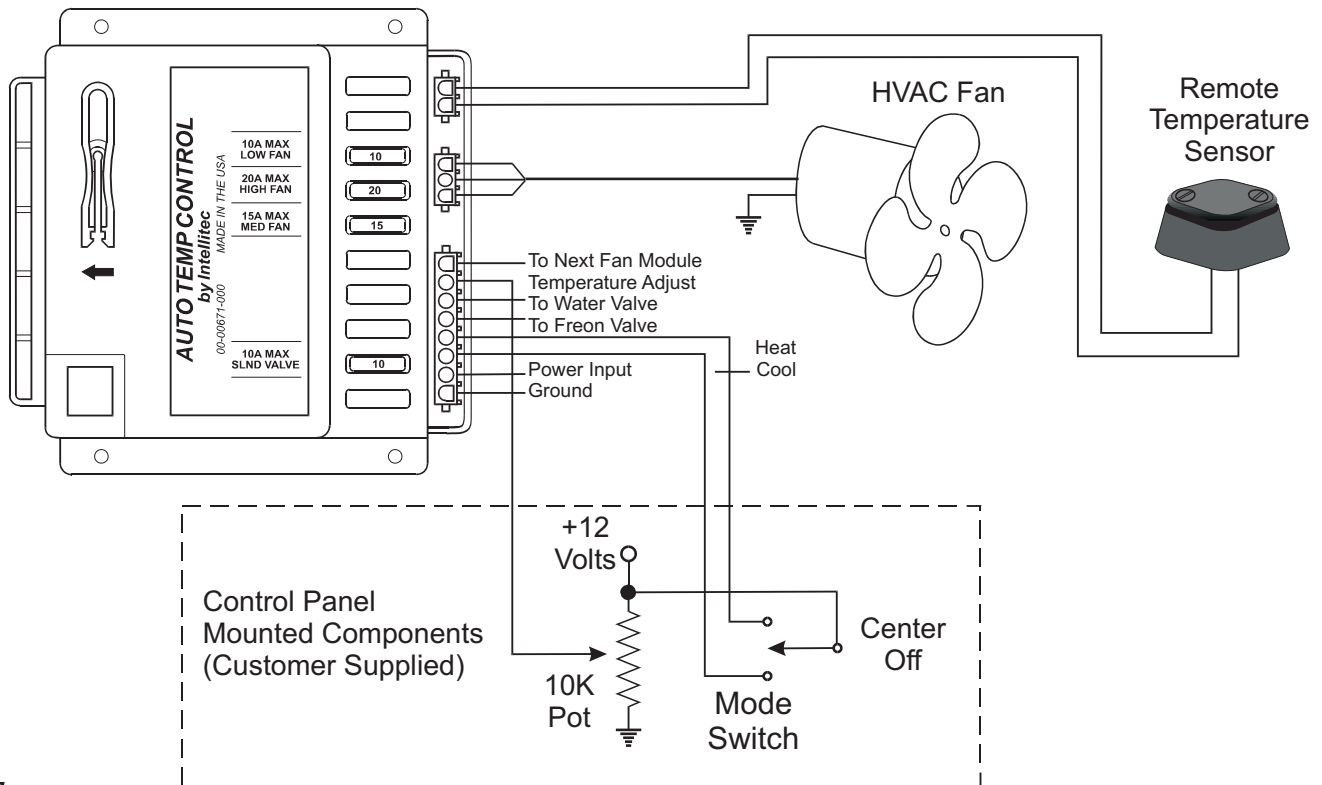

Intellitec

131 Eisenhower Lane North
 Lombard, IL 60148
 630.268.0010 / 1.800.251.2408
 FAX 630.916.7890

P/N 53-00671-000 Rev. B 030905